

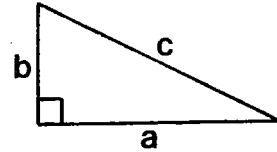

What Is the Title of This Picture?

For each exercise below, find the missing length. (Refer to the diagram at the right.) Find your answer in the answer column and notice the letter next to it. Each time the exercise number appears in the code, write this letter above it. Keep working and you will decode the title of the picture.



- ① $a = 8, b = 6, c = \underline{10}$
- ② $a = 4, b = 9, c = \underline{\sqrt{97}}$
- ③ $a = 12, b = 12, c = \underline{\sqrt{288}}$
- ④ $a = 7, b = \sqrt{20}, c = \underline{\sqrt{69}}$
- ⑤ $a = \sqrt{175}, b = 15, c = \underline{20}$
- ⑥ $a = \underline{\sqrt{75}}, b = 5, c = 10$
- ⑦ $a = 12, b = \underline{5}, c = 13$
- ⑧ $a = \underline{\sqrt{140}}, b = \sqrt{56}, c = 14$
- ⑨ $a = 1.5, b = \underline{2}, c = 2.5$
- ⑩ $a = \sqrt{85}, b = \sqrt{59}, c = \underline{12}$
- ⑪ $a = \underline{\sqrt{34}}, b = 6, c = \sqrt{70}$
- ⑫ $a = 40, b = \underline{9}, c = 41$
- ⑬ $a = 1, b = 1, c = \underline{\sqrt{2}}$
- ⑭ $a = \underline{1}, b = \sqrt{2}, c = \sqrt{3}$

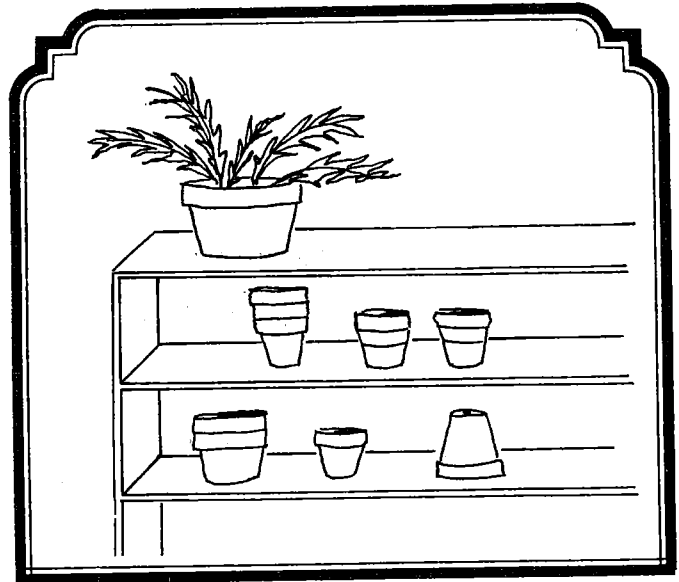

CODED TITLE:

S H E L V E S W I T H A
 11 14 5 10 8 5 11 4 13 2 14 6

H I G H P O T I N U S E
 14 13 1 14 12 3 2 13 7 9 11 5

E $\sqrt{400} = 20$	P $\sqrt{81} = 9$	N $\sqrt{25} = 5$
R $\sqrt{67} \doteq 8.19$	G $\sqrt{100} = 10$	J $\sqrt{2} \doteq 1.41$
S $\sqrt{34} \doteq 5.83$	O $\sqrt{288} \doteq 16.97$	W $\sqrt{69} \doteq 8.31$
T $\sqrt{97} \doteq 9.85$	L $\sqrt{144} = 12$	U $\sqrt{4} = 2$
V $\sqrt{140} \doteq 11.83$	H $\sqrt{1} = 1$	A $\sqrt{75} \doteq 8.66$

How Do You Write a Song That Will Knock Over a Cow?



Solve each problem below. Cross out the box that contains your answer. When you finish, print the letters from the remaining boxes in the spaces at the bottom of the page.

- ① For each right triangle, find the length of the side that is not given:

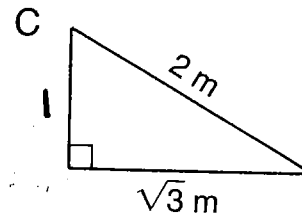
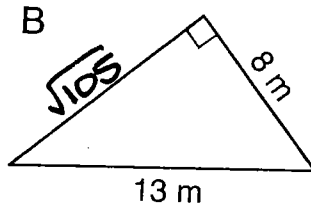
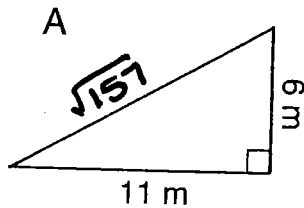

- ② A rectangle is 7 cm wide and 10 cm long. Find the length of a diagonal of the rectangle.

$$7^2 + 10^2 = c^2$$

$$\sqrt{149} = c$$

- ③ Each side of an equilateral triangle measures 30 cm. Find the length of an altitude, a , of the triangle.

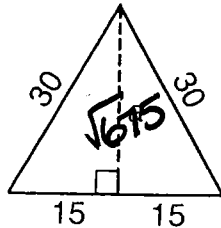

- ⑤ A 20-foot ladder is leaned against a wall. If the base of the ladder is 8 feet from the wall, how high up on the wall will the ladder reach?

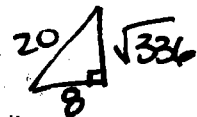

- ⑥ The bases of a softball diamond are 60 feet apart. How far is it from home plate to second base?

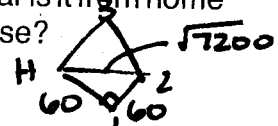

- ④ A television set may be described in terms of the diagonal measure of its screen. If a TV screen is 16 inches by 12 inches, what is the length of its diagonal?

$$12^2 + 16^2 = c^2$$

$$20 = c$$

- ⑦ Jack has let out 40 m of kite string when he observes that his kite is directly above Jill. If Jack is 25 m from Jill, how high is the kite?

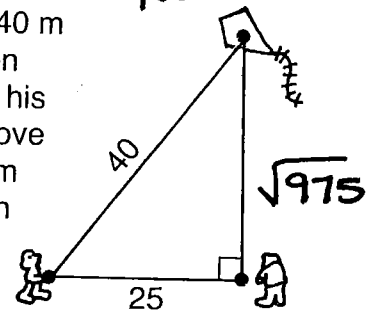

BY $\sqrt{7200}$ ft ≈ 84.9 ft	<u>IN</u> $\sqrt{123}$ m ≈ 11.1 m	SO $\sqrt{105}$ m ≈ 10.2 m	TH $\sqrt{675}$ cm ≈ 26.0 cm	<u>BE</u> $\sqrt{6400}$ ft = 80 ft	AT $\sqrt{975}$ m ≈ 31.2 m	ER $\sqrt{149}$ cm ≈ 12.2 cm
<u>EF</u> $\sqrt{850}$ m ≈ 29.2 m	OR $\sqrt{336}$ ft ≈ 18.3 ft	NG $\sqrt{157}$ m ≈ 12.5 m	<u>FL</u> $\sqrt{425}$ cm ≈ 20.6 cm	IT $\sqrt{1}$ m = 1 m	BE $\sqrt{400}$ in. = 20 in.	<u>AT</u> $\sqrt{380}$ in. ≈ 19.5 in.
I N B E E F F L A T						